

SPECIAL: FOLD-OUT CHART ON HI-FI SOUND

ELECTRONICS
WORLD

\$100

hi-fi

MAC

ANNUAL

& AUDIO HANDBOOK

1960

Design Your Own Hi-Fi Crossover

Build a Low Cost Stereo System

Loudspeakers for Stereo

How to Get Better Hi-Fi

Over 40 Pages on

STEREO

Amplifiers & Equipment



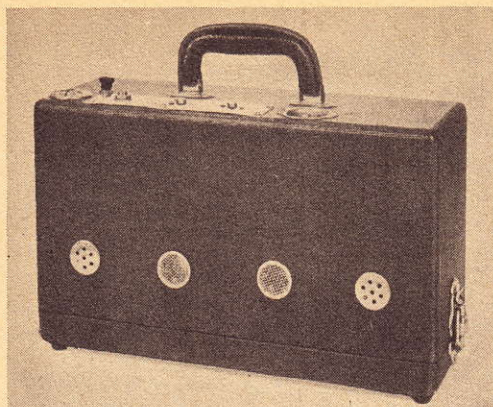

Audio "Mix-It" Box

By LEON A. WORTMAN

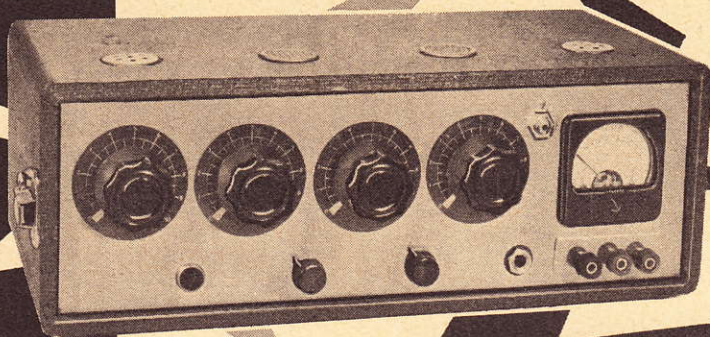

Operating panel of the "Mix-It" box is shown here. With cover in place, unit is portable.

IF THE signal is at an audio frequency, this versatile mixer-pre-amplifier can handle it very nicely. In fact, it will "handle" four separate audio signal sources at one time. With it, the operator can mix or blend or balance such diverse signals as those from these sources: low-impedance microphone (50 to 250 ohms); high-impedance microphone (above 500 ohms); reluctance-type phono cartridge; and utility (bridging) from any impedance source. Yes, microphones, tuners, tape players, phonographs, oscillators, or radio lines—high or low gain, high or low impedance—whatever the source, the "Mix-It" provides an excellent means of controlling signal level with both visual and aural monitoring.

This versatile mixer-preamplifier will handle four separate audio signal sources at one time.

Included in the circuit are: a db meter and meter attenuator, a phone jack, output terminals, plus all manual controls mounted on the front panel for easy handling and viewing. The output terminals are three thumb-screw binding posts. One is common and isolated from the chassis, the other two are for connection to an 8-ohm voice coil and a 500-ohm line. All input connectors are at rear of cabinet.

Power is provided by a built-in transformer-type a.c. supply. The entire "Mix-It" box measures only 14" wide, 8" deep, and 5" high when closed in its

carrying case. You see, it is portable too! Total weight is a mere 7 pounds.

The chassis is a standard 13" x 7" x 1½" open-end aluminum unit. The cabinet is a fabric-covered wood box obtained from a local photo-supply store at very low cost. The box was originally designed as a carrying case for a 35 mm slide projector. The inside dimensions proved ideal for the standard chassis being used. The panel was cut from aluminum stock to fit the front opening of the carrying case. Other cases can be used, of course, in conjunction with standard-size aluminum or steel chassis. The panel is secured to the chassis by the hex nuts of the "on-off" switch, pilot light, master gain control, and the hardware of the output terminal strip. For an attractive and distinctive appearance, after the panel had been drilled and cut, the panel was sprayed with gold lacquer. One of the handy spray cans, available at radio parts houses and many hardware stores, was used for the purpose. Other colors, such as the familiar grays and blacks, and hamertone sprays are also available. Their application is simple and certainly enhance the appearance of the equipment.

The tube line-up and functions are as follows, referred to the schematic diagram of Fig. 1: V_{1A} preamplifies the low-impedance microphone-level signals from input transformer T_1 ; V_{1B} preamplifies the signals of the high-impedance microphone or crystal-type

Top-chassis view of the unit shows that all tubes, except rectifier, are shielded.

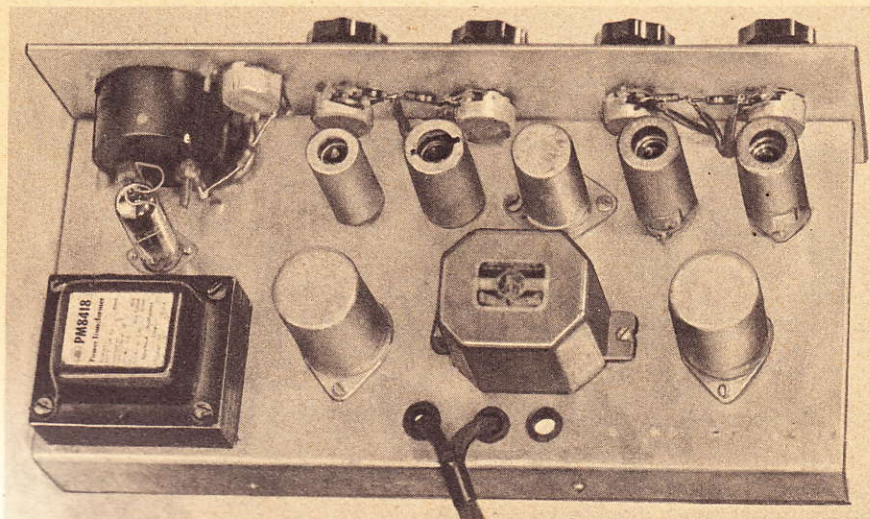

NOTE: ALL GROUND CONNECTIONS ARE MADE TO A COMMON BUS WHICH IS THEN GROUNDING AT A SINGLE POINT, SEE TEXT

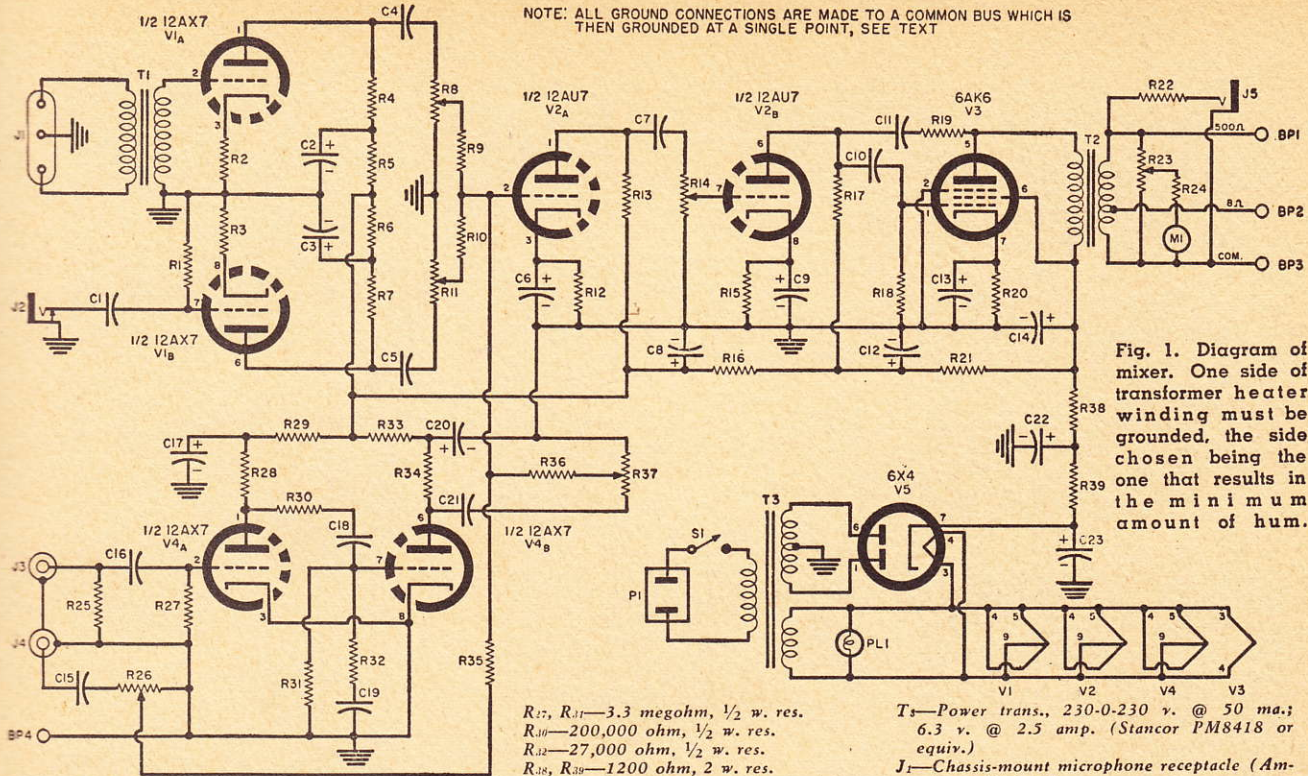

Fig. 1. Diagram of mixer. One side of transformer heater winding must be grounded, the side chosen being the one that results in the minimum amount of hum.

- R₁, R₁₈—470,000 ohm, 1/2 w. res.
- R₂, R₃, R₁₅, R₂₂—1500 ohm, 1/2 w. res.
- R₄, R₇, R₈, R₉, R₃₅, R₃₆—100,000 ohm, 1/2 w. res.
- R₅, R₆, R₂₃, R₂₄—33,000 ohm, 1/2 w. res.
- R₈, R₁₁, R₁₁, R₂₅, R₃₇—500,000 ohm pot
- R₁₂—2200 ohm, 1/2 w. res.
- R₁₃, R₁₇, R₂₈, R₂₉—68,000 ohm, 1/2 w. res.
- R₁₆, R₂₁, R₂₄—3900 ohm, 1 w. res.
- R₁₉—39,000 ohm, 1 w. res.
- R₂₀—560 ohm, 1/2 w. res.
- R₂₅—10,000 ohm pot
- R₃₅—15,000 ohm, 1/2 w. res.

- C₁, C₃, C₅, C₇, C₂₁—.02 μfd., 400 v. tubular capacitor
- C₂—C₁—C₁₇—C₂₀, C₈—C₁₂—C₁₄—C₂₃—10/10/10 μfd., 450 v. elec. capacitor
- C₆—C₉—C₁₃—20/20/20 μfd., 25 v. elec. capacitor
- C₁₀, C₁₆, C₁₈—.05 μfd., 400 v. tubular capacitor
- C₁₁, C₁₅—.1 μfd., 600 v. tubular capacitor
- C₁₉—.01 μfd., 400 v. tubular capacitor
- C₂₂—16 μfd., 450 v. elec. capacitor
- T₁—Microphone trans., low impedance to grid (UTC O-1 or equiv.)
- T₂—Universal output to line trans., 10,000 ohms to 500 ohms (UTC S-15 or equiv.)

- T₃—Power trans., 230-0-230 v. @ 50 ma; 6.3 v. @ 2.5 amp. (Stancor PM8418 or equiv.)

- J₁—Chassis-mount microphone receptacle (Amphenol XL-3-13)
- J₂—Closed-circuit phone jack
- J₃, J₄—Phono pin jack
- J₅—Open-circuit phone jack
- BP₁, BP₂, BP₃, BP₄—Binding post
- P₁—A.c. receptacle (Amphenol 61M10)
- S₁—S.p.s.t. switch (author used rotary unit)
- PL₁—6.3 v. pilot light
- M₁—Decibel meter
- V₁, V₄—12AX7 tube
- V₂—12AU7 tube
- V₃—6AK6 tube
- V₅—6X4 tube

phono cartridge; V_{1A} and V_{1B} preamplify and bass-compensate the output of a reluctance-type phono cartridge; V_{2A} and V_{2B} are in series-connected circuits as voltage amplifiers driving V₃, a 6AK6 power pentode. Maximum audio power output available is approximately .8 watt into a 500-ohm load; V₅ is a 6X4 full-wave rectifier tube for the power supply.

The "Mix-It" box was originally constructed for use with a remotely located tape recorder of professional quality, therefore the db meter, meter attenuator, and multiple outputs were required. These features are not often found in equipment other than that designed for commercial recording or broadcast work. The db meter and meter attenuator enable the "setting of levels" when the operator of the "Mix-It" and the recorder are physically separated. This permits the adjustment of volume controls during a "feed" or a "pickup" for optimum performance with respect to distortion (by controlling possibilities of overloading) and background noise (by maintaining a relatively high minimum level of the audio signal consistent with good dynamic range). Frequency response of the "Mix-It" is shown in Fig. 2.

The output level of the "Mix-It" is

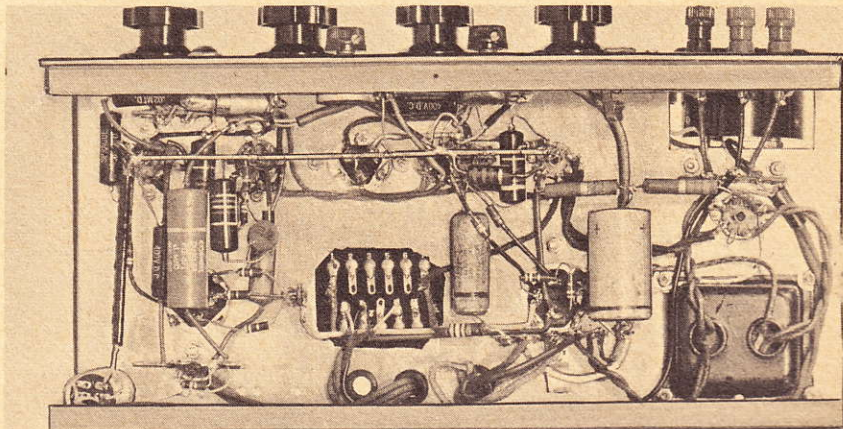

Bottom-chassis view of the audio "Mix-It" unit. Note use of a ground bus.

At rear of the carrying case are the power plug and various input jacks.

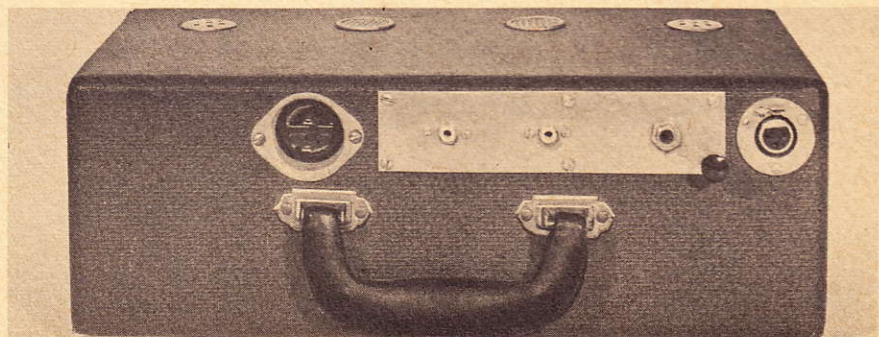

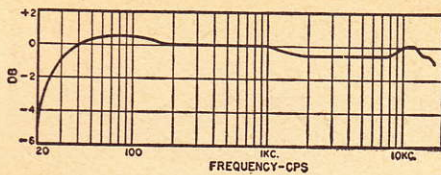

Fig. 2. Over-all response curve of mixer.

sufficient to drive a small monitor loudspeaker connected to the 8-ohm output terminals. This permits the equipment to be used for a number of additional purposes. It can be used as a playback amplifier for tapes or discs, as an entertainment amplifier for listening to a radio tuner or record player, or to monitor the signal during an "off the air" recording, or to monitor tape or disc dubbing sessions.

The input connections are mounted on a small strip of metal at the back of the box. The low-impedance microphone receptacle is an *Amphenol* type frequently used with such equipment. The high-impedance microphone plugs into a standard normally closed, single-circuit phone jack. The inputs for the reluctance cartridge and the bridging connector are pin-type phono jacks. A thumb-screw binding post provides a convenient means of connection to the common ground bus, sometimes found necessary for minimizing "ground loops." Note that the ground is *not* carried through the output terminals. All cables from the input terminal strip to the chassis are flexible and shielded for long life and minimum hum pickup from this source. The a.c. line cord plugs into the back of the cabinet. When the "Mix-It" is not in use or is being transported, the power cord can be folded up and stored inside the cover of the cabinet.

With care in wiring, hum and oscillation should not present a problem. Filament wiring, as is good practice, should be done first and should "hug" the chassis. A common ground bus, No. 12 tinned wire, is run about $\frac{1}{2}$ " in space above the pins of the audio tubes, from V_1 to V_4 . All ground connection for these stages should be made to the ground bus, with the cathode and grid resistors terminated at one point for each stage. The ground bus is connected to the chassis at one point only. Experiment will quickly locate that point which gives best results, that is, minimum hum. A small screwdriver, placed against the ground bus and the chassis, is moved along until the optimum grounding point is indicated. In this particular construction that point was determined to be at the approximate center of the ground bus, where the three-section electrolytic, $C_6-C_9-C_{13}$, is mounted. Vent plugs are mounted at the top of the cabinet directly above the tubes. In addition to providing air flow, they enable rapid visual inspection of the tubes with respect to filament glow, just in case some trouble should develop.

Storing YOUR Small Components

By FORREST H. FRANTZ, SR.

Keep your small items in corrugated "parts cards."

THE serious transistor experimenter has a problem. His problem is storing transistors and miniature parts. Other problems associated with this one are: (1) what kind and how many of each part does he have on hand and (2) what are the basic characteristics of transistors of a certain type?

The problem is not peculiar to the experimenter. The matter of control is even more important to radio and TV technicians, laboratory stock room personnel, and distributors. A system of control which hinges on physically seeing the parts in stock is ideal—if the parts are assembled into a physically small space and counting can be done rapidly. A very good answer to the problem occurred to the author, triggered by *Sylvania* which shipped transistors stuck into corrugated paper sheets such as those often used between layers of candy and cookies in commercial packages. The author tried to obtain some of this corrugated paper locally but couldn't find any in a hurry.

A decision was then made to improvise "parts cards" out of corrugated cardboard cut from shipping boxes and pasted on pieces of stiff cardboard which served as backing and provided writing space for component identification and characteristic information.

These "parts cards", as employed by the author in this case, vary in size. This was done to facilitate location. A rubber band around the card helps to keep resistors and other "two ended" parts such as capacitors in place. With small components stored on cards like this, they can be filed in a very small space, all conveniently separated and tagged. The author's small parts file shown in Fig. 1, can hold over 100 transistors, about 400 resistors, about 100 small ceramic capacitors, and approximately 100 small electrolytic capacitors for transistor work without cramping. The box is only about 6 inches wide by 9 inches long!

Fig. 1. Photo of author's small parts file.

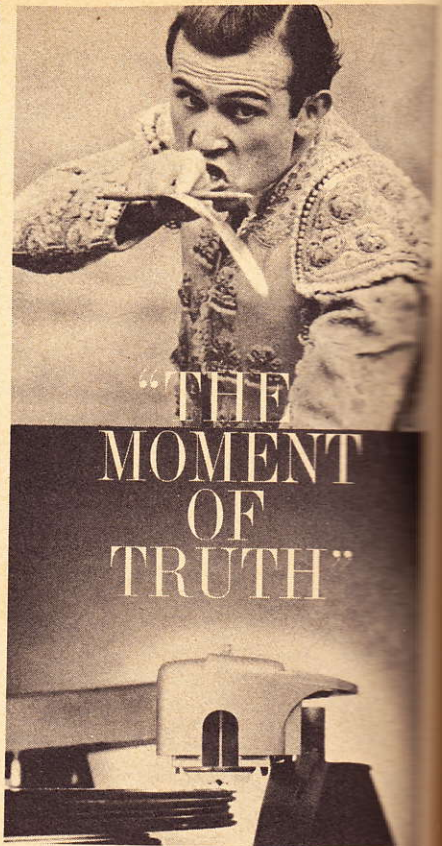
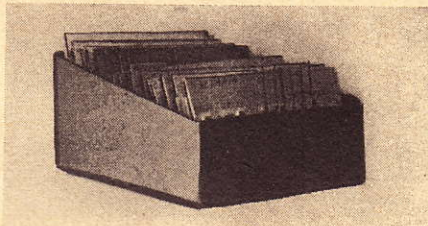

... for the matador — it comes when he must at last face up to the supreme test of his courage and greatness.

... for the turntable or changer — it comes when the stylus descends to the groove of a stereo record, to track as never before required ... vertically as well as laterally, with lighter pressure, greater accuracy, less distortion and far more sensitivity — when the operation must be silent, smooth and flawless to permit the music to emerge with clarity, purity and distinction.

Shorn of pretension and mere paper claims, every brand, every product of old must now face up to the new challenge wrought by stereophonic sound. Regardless of past laurels, it is *today's* performance that counts.

Totally new, significantly different ... the DUAL-1006 is the only combination professional turntable and deluxe changer created for uncompromised stereo and monophonic reproduction. Visit your United Audio dealer and see and hear the DUAL-1006 in its "moment of truth."

the UNITED AUDIO

DUAL 1006

COMBINATION STEREO
TURNTABLE/CHANGER